

SCOTT Speedster 20



Frame
Speedster Aero / D.Buttet 6061 Alloy /
Road geometry / Integrated Headtube

Spokes
HTI - Standard
Black 2mm

Fork
Speedster Carbon/Alloy
1 1/8" Alloy steerer

Rims
Syncros Race 27 Aero Profile
20 Front / 24 Rear

Headset
Integrated Steel Cup

Tires
Kenda Kontender
700x25C

Rear Derailleur
Shimano 105 Black RD-5800-GS
22 Speed

Weights in KG
9.2

Front Derailleur
Shimano 105 Black FD-5800

System Weight
120 kg
Le poids total inclus le vélo, le poids du
cycliste, son équipement et des éventuels
accessoires.

Shifters
Shimano 105 Black ST-5800
Dual control 22 Speed

Brakes
Shimano BR-R561 Black
Super SLR Dual pivot

Crankset
Shimano FC-RS500 Black
Hyperdrive 34x50 T

BB-Set
Shimano BB - RS500

Handlebar
Syncros RR2.0
Anatomic 31.8mm

H'stem
Syncros FL2.0
1 1/8" / four Bolt 31.8mm

Seatpost
Syncros RR1.4 Carbon/AL 31.6mm

Seat
Syncros FL2.5

Hub (Front)
Formula Team 20 H

Hub (Rear)
Formula Team 24 H

Chain
KMC X11

Cassette
Shimano 105 CS-5800
11 Speed 11-32 T



Le SCOTT Speedster 20 est conçu à partir de tubes en aluminium multi épaisseur. Le cadre adopte une géométrie taillée pour la compétition tout en offrant un réel avantage aérodynamique et des performances hors du commun à un prix réduit.

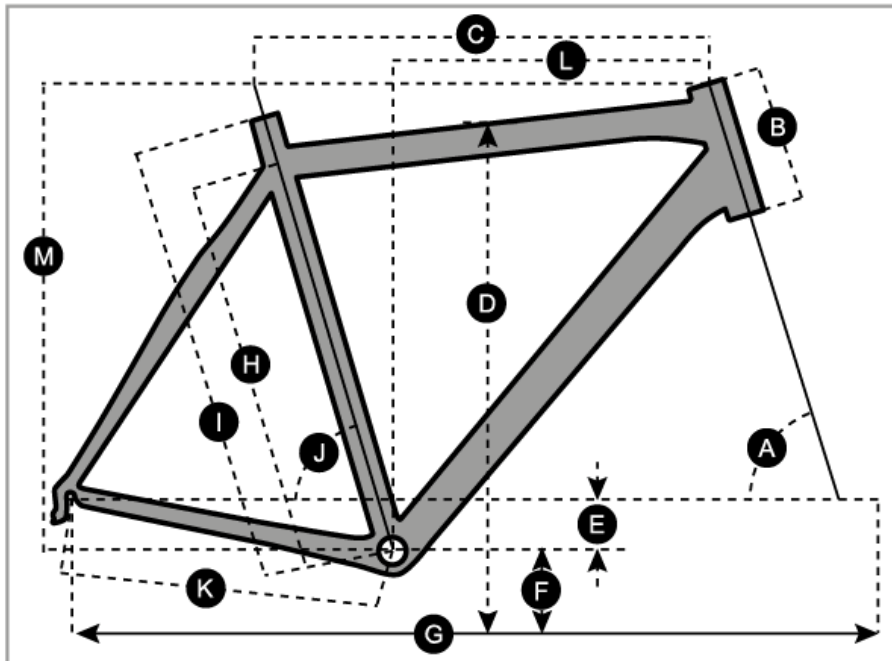

SPEEDSTER

	XXS/47	XS/49	S/52	M/54	L/56	XL/58	XXL/61
A head tube angle	70.5 °	71.0 °	73.0 °	73.0 °	73.0 °	73.0 °	73.0 °
B head tube length	111.0 mm	116.0 mm	136.0 mm	156.0 mm	176.0 mm	196.0 mm	216.0 mm
C top tube horizontal	505.0 mm	515.0 mm	530.0 mm	545.0 mm	560.0 mm	575.0 mm	595.0 mm
D standover height	722.0 mm	736.0 mm	763.0 mm	782.0 mm	802.0 mm	820.0 mm	845.0 mm
E BB offset	-67.0 mm	-67.0 mm	-67.0 mm	-67.0 mm	-67.0 mm	-67.0 mm	-67.0 mm
F BB height	272.0 mm	272.0 mm	272.0 mm	272.0 mm	272.0 mm	272.0 mm	272.0 mm
G wheel base	973.0 mm	979.0 mm	971.0 mm	982.0 mm	992.0 mm	1,004.0 mm	1,025.0 mm
H BB center to toptube center	410.0 mm	430.0 mm	460.0 mm	480.0 mm	500.0 mm	520.0 mm	550.0 mm
I BB center to top of seattube	470.0 mm	490.0 mm	520.0 mm	540.0 mm	560.0 mm	580.0 mm	610.0 mm
J seat angle	75.0 °	75.0 °	74.5 °	74.0 °	73.5 °	73.3 °	73.3 °
K chainstay	405.0 mm	405.0 mm	405.0 mm	405.0 mm	405.0 mm	405.0 mm	405.0 mm
L reach	368.0 mm	376.0 mm	379.0 mm	383.0 mm	387.0 mm	394.0 mm	409.0 mm
M stack	513.0 mm	519.0 mm	545.0 mm	565.0 mm	584.0 mm	603.0 mm	620.0 mm
N stem length	80.0 mm	90.0 mm	100.0 mm	110.0 mm	110.0 mm	120.0 mm	120.0 mm

SIZE CHARTS

Body Height	< 165 cm	165 - 175 cm	175 - 185 cm	185 - 195 cm	> 195 cm
SPARK 700/900 E-SPARK 700 (S-L) GENIUS 700/900 E-GENIUS 900	S	M	L	XL	
SCALE / SPARK 700 PLUS GENIUS 700/LT PLUS (S-L) E-GENIUS PLUS	S	M	L	XL	
CONTESSA SPARK / SCALE 700 RC CONTESSA GENIUS 700 (S-L) CONTESSA GENIUS 700	S	M	L	XL	
GAMBLER 700	S	M	L		
GENIUS LT700	S	M	L		
SCALE 700/900 BIG ED/BIG JON	S	M	L	XL	
VOLTAGE FR		S	L		
VOLTAGE YZ 10-20	XS	M	L	XL	
ASPECT 600 (XS-XL) ASPECT 700 (XS-XL) ASPECT 900 (S-XXL) E-ASPECT 900 (S-XL)	XS	M	L	XL	
FOIL ADDICT CRI SPEEDSTER (INCLUDING DISC) SOLACE	XXS	S	M	L	XL
CONTESSA SOLACE CONTESSA SPEEDSTER	XXS	S	M	L	
ADDICT/SPEEDSTER CX	XS	M	L	XL	
CONTESSA FOIL/CONTESSA ADDICT/ CONTESSA CRI/CONTESSA SPEEDSTER	XXS	S	M	L	
E-SUB/SUB EVO E-SUB/SUB SPORT MENS E-SUB/SUB COMFORT MENS E-SUB/SUB TOUR SUB CROSS MEN PLASMA 4/5	XS	M	L	XL	
CONTESSA ACTIVE	XS	M	L		
SUB COMFORT LADY UNISEX (S-L) SUB CROSS LADY (S-XL)	S	M	L	XL	

JUNIOR

Body Height	80-95 cm	95-120 cm	120-130 cm	130-145 cm	> 145 cm
Approximate Age	2-4	4-6	6-9	9-11	11-12+
VOLT-X			Wheel 20"	Wheel 20"	Wheel 20"
SPEEDSTER JR				Wheel 24"	
SCALE			Wheel 20"	Wheel 24"	Wheel 26"
VOLTAGE	Wheel 12"	Wheel 16"	Wheel 20"	Wheel 24"	Check adult range
CONTESSA JR	Wheel 12"	Wheel 16"	Wheel 20"	Wheel 24"	Check adult range
WALKER	Wheel 12"				